

Other series

Nitrogen gas springs for dies / *Cilindri all'azoto per stampi*



MIC

Diameter 25 mm ready-to-use gas springs, charged at five different initial forces: 50 daN, 100 daN, 150 daN, 200 daN and 300 daN (NEW MODEL).

Cilindri di diametro 25 mm già caricati e pronti per l'uso in cinque diverse forze iniziali standard: 50 daN, 100 daN, 150 daN, 200 daN e 300 daN (NUOVO MODELLO).

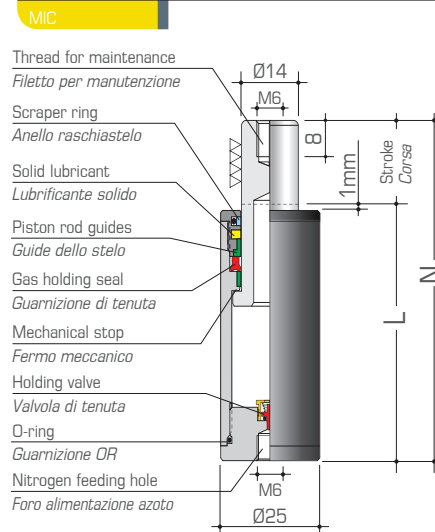

TECHNICAL NOTES

Important use instructions on pages 10 & 11

End-stroke force is 1.6 times the initial force.

How to order

8 MIC25-25-F150

No. 8 nitrogen gas springs MIC \varnothing 25 mm, stroke 25 mm, initial force 150 daN.

NOTE TECNICHE

Importanti istruzioni d'uso alle pagine 10 e 11

La forza a fine corsa è pari a 1,6 volte la forza iniziale.

Esempio d'ordine

8 MIC25-25-F150

N° 8 cilindri all'azoto MIC \varnothing 25 mm, corsa 25 mm, forza iniziale 150 daN.

MODEL MODELLO	MAX STROKE mm CORSA MAX mm	L mm	N mm	...F50		...F100		...F150		...F200		...F300	
				bar	daN	bar	daN	bar	daN	bar	daN	bar	daN
MIC25-10- ...	10	50	60										
15- ...	15	55	70										
25- ...	25	65	90										
38- ...	38	78	116	32	50	65	100	97	150	130	200	195	300
50- ...	50	90	140										
80- ...	80	120	200										